

BEIJING HUADE HYDRAULIC INDUSTRIAL GROUP CO.,LTD.	Check-Q-meter, type DC			RE 25810/12.2004
	Size 10 to 30	up to 31.5 MPa	up to 330 L/min	Replaces, RE25810/05.2001

Features:

- For subplate mounting
- For pipe connections
- 5 pressure ranges
- 3 adjustment elements:
 - Rotary knob
 - Sleeve with hexagon and protective cap
 - Lockable rotary knob with scale



Functional,section

The valves consist basically of the housing(1), direct operated poppet valve(2), and check valve(3).

Check-Q-meters are used in hydraulic systems to prevent negative loads causing hydraulic cylinders or motors "running away". They may also act as anti-burst valves.

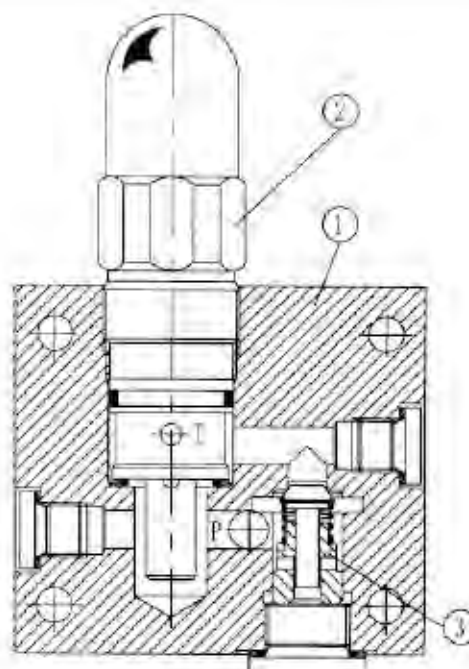

Type DC...10B/...

Symbols

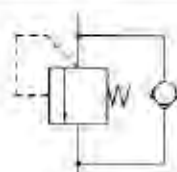

Type DC...10/...

Ordering Code

DC - - 10 B / - *

Size	Subplate mounting	Pipe connections
6	-	M14X1.5: G1/4"
10	10	M22X1.5: G1/2"
15	-	M27X2: G3/4"
20	20	M33X2: G1"
25	-	M42X2: G1 1/4"
30	30	M48X2: G1 1/2"

Subplate mounting	=P
Pipe connections	=G

Rotary knob	=1
Sleeve with hexagon and protective cap	=2
Lockable rotary knob with scale	=3

Further details in clear text

No code = mineral oils
V = phosphate ester

25 = Pressure adjustable up to 2.5 MPa
50 = Pressure adjustable up to 5 MPa
100 = Pressure adjustable up to 10 MPa
200 = Pressure adjustable up to 20 MPa
315 = Pressure adjustable up to 31.5 MPa

B= Technology of Beijing Huade Hydraulic

10 = Series 10 to 19
(10 to 19 = unchanged installation and connection dimensions)

Technical data (For applications outside these parameters, please consult us!)

Pressure fluid	Mineral oil (for NBR seal) or phosphate ester (for FPM seal)					
Pressure fluid - temperature range (°C)	-30 to +80					
Viscosity range (mm ² /s)	10 ~ 800					
Size	6	10	15	20	25	30
Operating pressure, ports A and B (MPa)	up to 31.5					
Cracking pressure (MPa)	up to 0.05					
Flow, max. (L/min)	45	110	230	330		
Degree of fluid contamination (µm)	Maximum permissible degree of contamination of the fluid is to NAS 1638, class 9. $\beta_{10} \geq 75$					

Characteristic curves (measured at V = 41 mm²/s and t = 50°C)

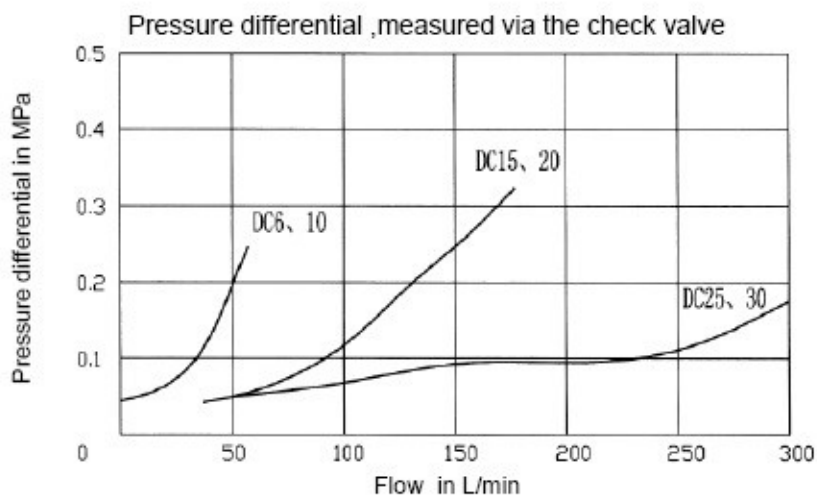

Characteristic curves (measured at $V = 41 \text{ mm}^2/\text{s}$ and $t = 50^\circ\text{C}$)

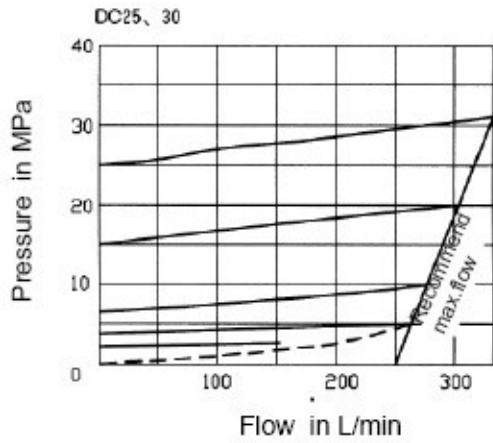
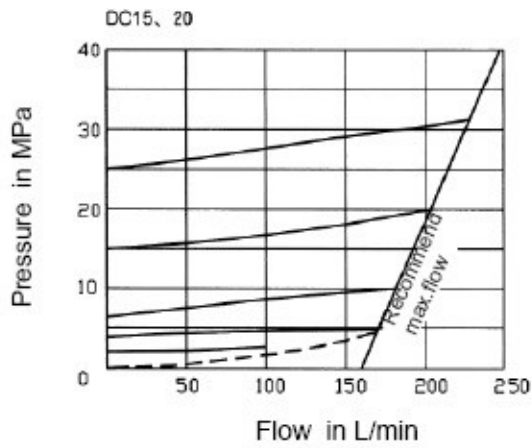
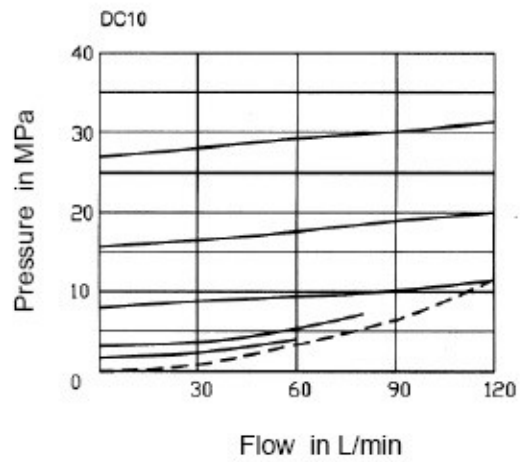
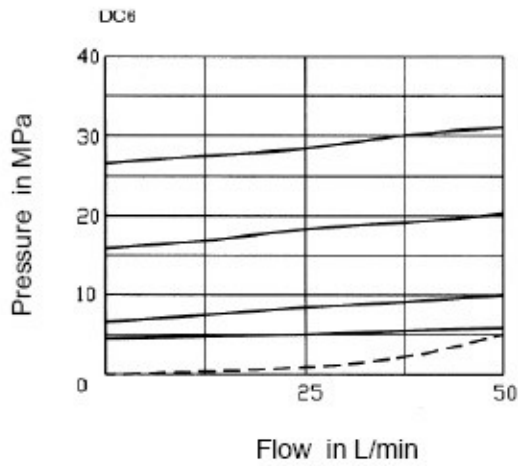

-----Min.adjusting pressure

Unit dimensions:Subplate mounting

(Dimensions in mm)

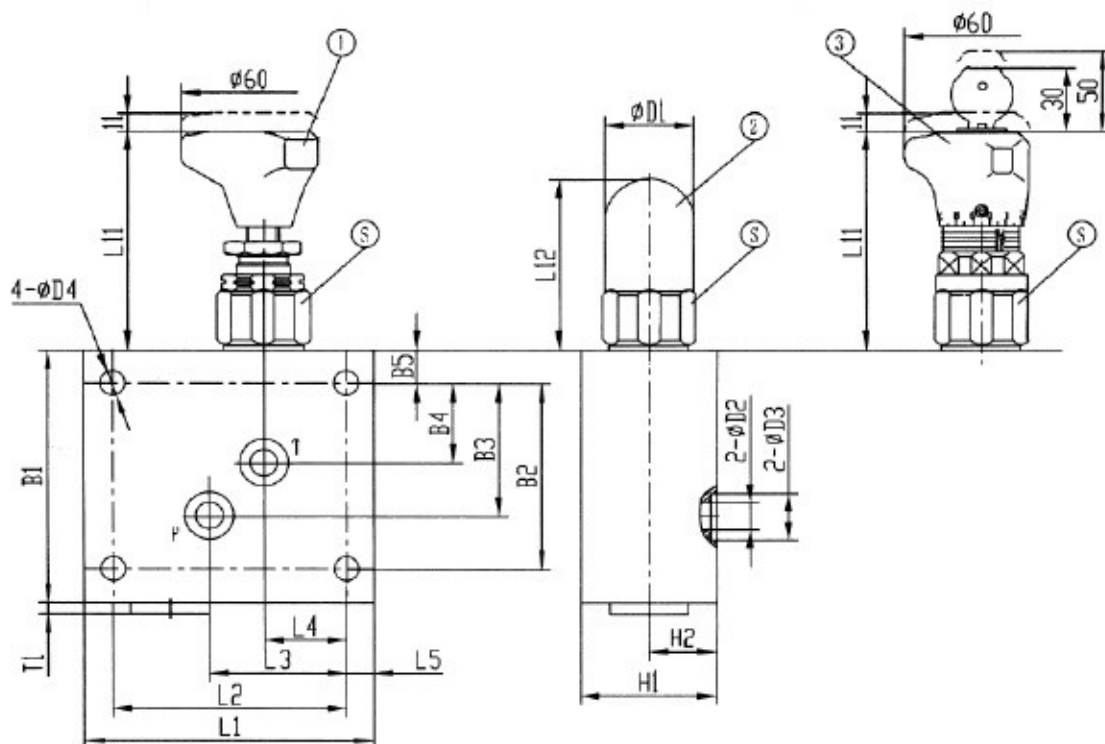

subplate mounting dimensions:

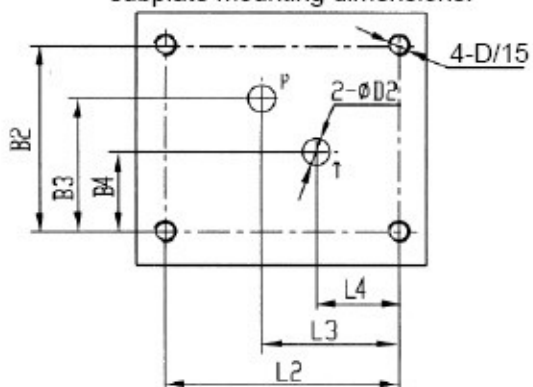

- 1.Rotary knob
- 2.Sleeve with hexagon and protective cap
- 3.Lockable rotary knob with scale

Size	L1	L2	L3	L4	L5	L11	L12	B1	B2	B3	B4	B5	H1	H2
10	105	85	50	30	10	79	68	95	70	50	30	12.5	50	25
20	145	115	65	35	15	77	65	135	85	63	29	25	60	30
30	180	150	75	45	15	-	83	175	125	82	35	25	80	40

Size	φ D1	φ D2	φ D3	φ D4	S	T1	D	O-ring	Fixed screw (GB/T70.1-2000)	Weight (Kg)
10	38	10	17.8	9	36	4	4-M8	12.3 × 2.4	4-M8 × 50-10.9	4
20	46	20	27.7	13	46	8	4-M12	22 × 3	4-M12 × 60-10.9	9
30	63	30	41.6	17	60	5	4-M16	34 × 3	4-M16 × 120-10.9	20

Unit dimensions: pipe connections

(Dimensions in mm)

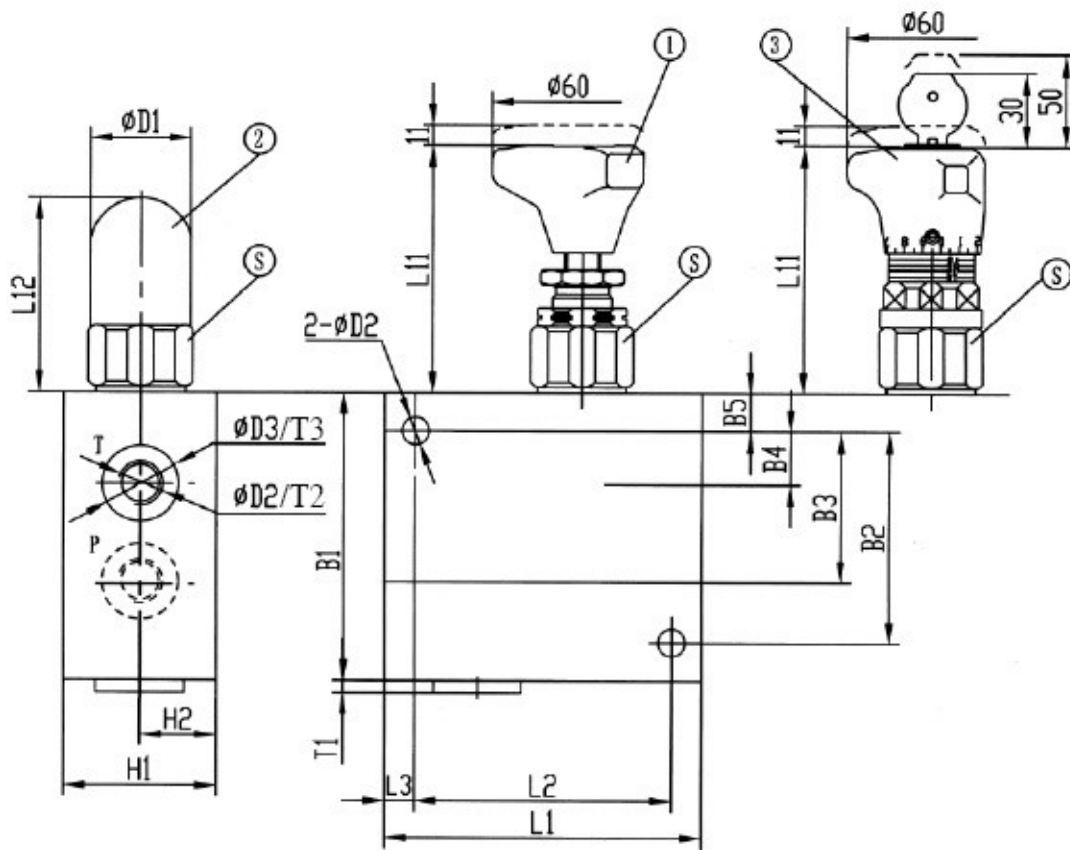

1. Rotary knob
2. Sleeve with hexagon and protective cap
3. Lockable rotary knob with scale

Size	L1	L2	L3	L11	L12	B1	B2	B3	B4	B5	H1	H2	$\phi D1$
6	105	85	10	83	72	95	70	50	30	12.5	50	25	34
10				79	68								38
15	140	110	15	77	65	135	85	63	29	25	60	30	48
20													
25	180	150	15	-	83	175	125	82	35	25	80	40	63
30													

Size	$\phi D2$	$\phi D3$	D	S	T1	T2	T3	Weight (Kg)
6	9	25	M14 \times 1.5(G1/4 ")	32	4	16	1	4
10		38	M22 \times 1.5(G1/2 ")	33		15		
15	14	45	M27 \times 2(G3/4 ")	16	7	18	1	9
20		52	M33 \times 2(G1 ")			20		
25	18	63	M42 \times 2(G1 1/4 ")	60	8	23	1	20
30		65	M48 \times 2(G1 1/2 ")					

NOTICE

1. The fluid must be filtered. Minimum filter fineness is 20 μm .
2. The tank must be sealing up and an air filter must be installed on air entrance.
3. Products without subplate when leaving factory, if need them, please ordering specially.
4. Valve fixing screws must be high intensity level (class 10.9). Please select and use them according to the parameter listed in the sample book.
5. Roughness of surface linked with the valve is required to $\sqrt{0.8}$.
6. Surface finish of mating piece is required to 0.01/100mm.