

BEIJING HUADE HYDRAULIC INDUSTRIAL GROUP CO.,LTD.	Pressure relief valve, direct operated, type DBD			RE 25402/12.2004
	Size 6 to 30	up to 63 MPa	up to 330L/min	Replaces, RE 25402/05.2001

Features:

- As cartridge valve
- For threaded connections
- for subplate mounting
- 3 pressure adjustment elements, optional:
 - Rotary knob
 - Hex. head screw with protective cap
 - Lockable rotary knob with scale



Function, section

The DBD pressure relief valves are direct operated poppet valves.

They are used to limit the pressure in a hydraulic system.

The valves mainly consist of sleeve (1), spring (2), poppet with damping spool (4) (pressure stages 2.5 to 40 MPa) or ball (4) (pressure stage 63 MPa) and adjustment element (3). The setting of the system pressure is infinitely variable via the adjustment element (3). The spring (2) pushes the poppet (4) onto the seat. The P channel is connected to the system. The pressure present in the system is applied to the poppet area (or ball).

If the pressure in channel P rises above the valve set at the spring (2), the poppet (4) opens against the spring (2). Now pressure fluid flows from channel P into channel T. The stroke of the poppet (4) is limited by a pin.

In order to maintain a good pressure settings over the entire pressure range the pressure range is split into 7 pressure stages. One pressure stage corresponds to a certain spring for a maximum operating pressure which may be set with it.

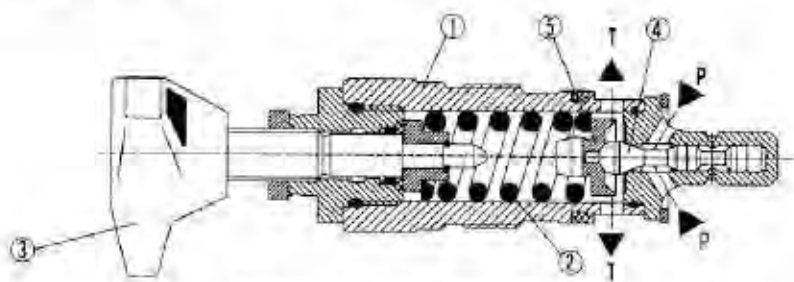

DBDH...K...10B/...(poppet valve)

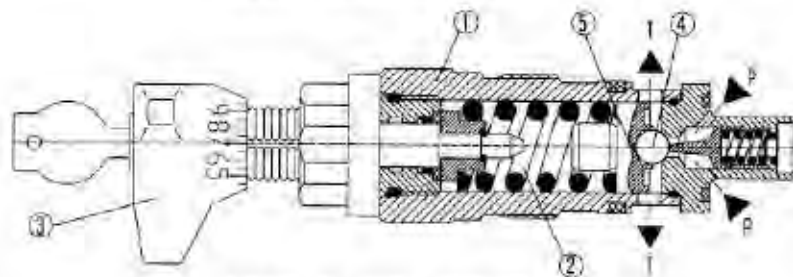

DBDA...K...10B/...(ball valve)

Type DBD ,direct operated pressure relief valve

Symbols

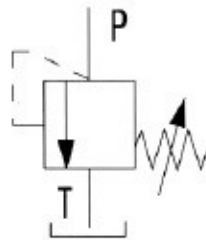

Simplified

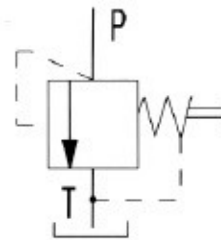

Detailed

Ordering details

DBD 10 B / / / *

Pressure relief valve direct operated = DBD

Further details in clear text

Adjustment element

Grub screw with hexagon and protective cap = S
 Rotary knob = H
 Lockable rotary knob (only to size 6.8 and 10) = A

No code = mineral oils
 V = phosphate ester

Size

Nominal size	G	K	P
6=	6	6	6
8=	8	-	-
10=	10	10	10
15=	15	-	-
20=	20	20	20
25=	25	-	-
30=	30	30	30

No code =
 2 = British metric

Pressure stage

	NG10	NG 6 to 20	NG 25 to 30
25	25	25	25
50	50	50	50
100	100	100	100
200	200	200	200
315	315	315	315
400	400	400	-
-	-	-	-

Type of connection

As cartridge valve (cartridge) = K
 For threaded connections = G
 For subplate mounting = P

B = Technology of Beijing Huade Hydraulic

Series 10 = 10
 (10 to 19: unchanged installation and connection dimensions)

Characteristic curves (measured at $v = 41\text{mm}^2/\text{s}, t=50^\circ\text{C}$)

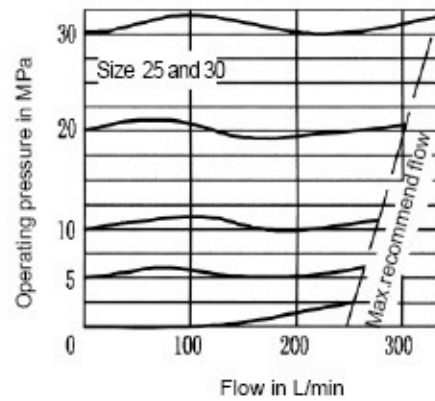
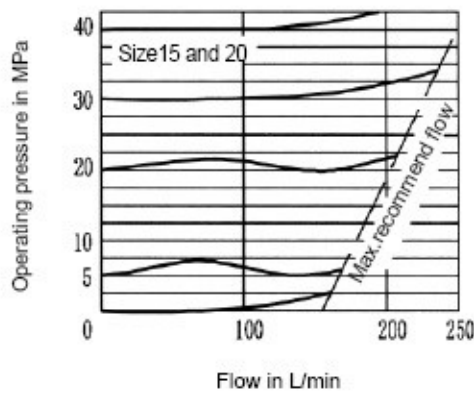
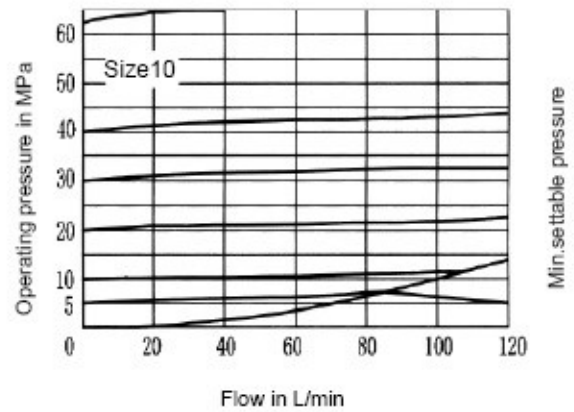
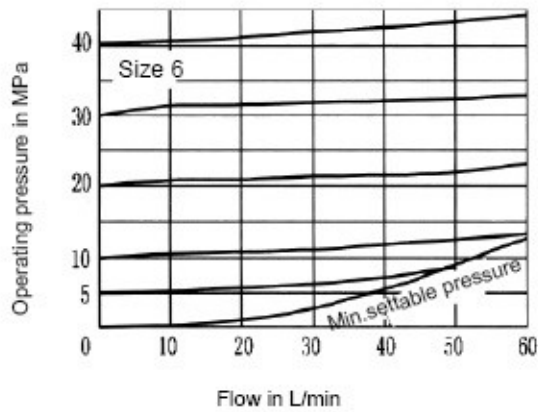

Hydraulic technical data

Size		6	8, 10	15, 20	25, 30
Operating pressure (MPa)	Port P	40	63	40	31.5
	Port T	31.5			
flow (L/min)		50	120	250	350
Pressure fluid		Mineral oil (for NBR seal), or phosphate ester (for FPM seal)			
Pressure fluid temperature range (°C)		-30 ~ +80			
Viscosity range (mm ² /s)		10 ~ 800			

Unit dimensions: cartridge valve

(Dimensions in mm)

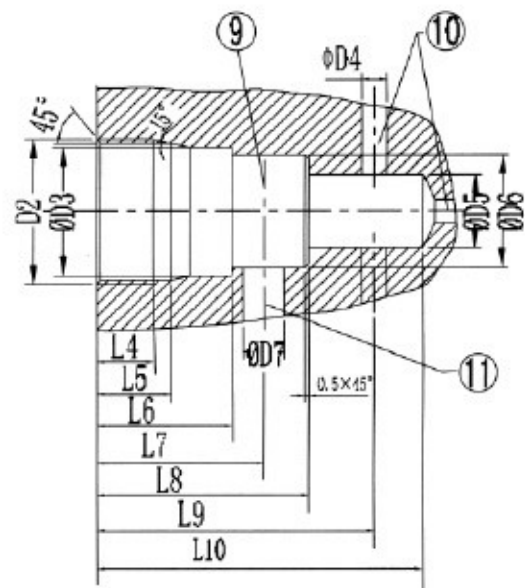
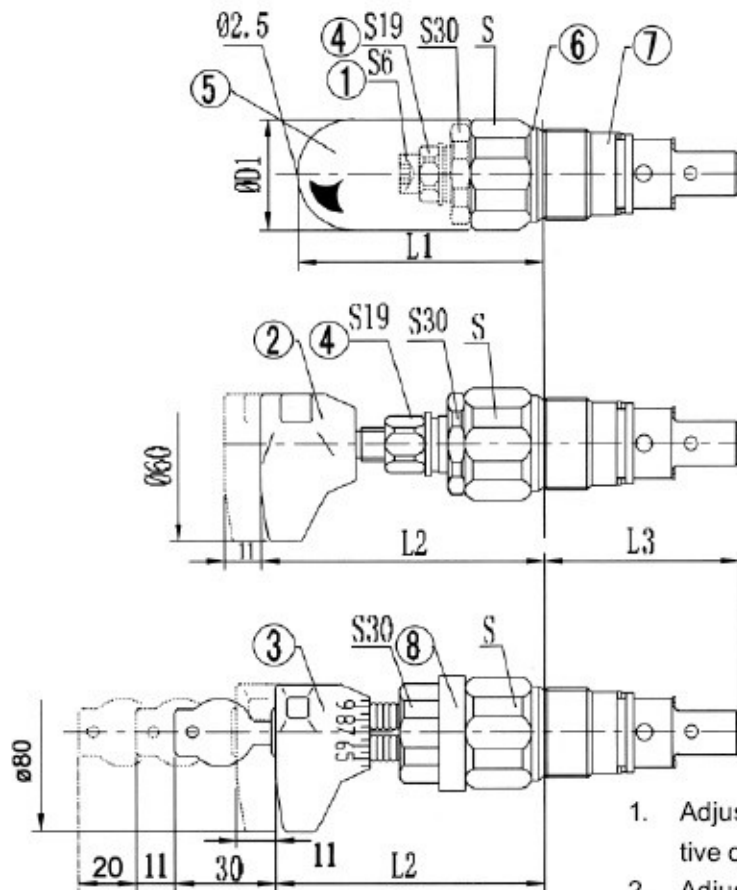

1. Adjustment element "S" hex. head screw with protective cap
2. Adjustment element "H" rotary knob
3. Adjustment element "A" lockable rotary knob (only to size 6, 8, 10)
4. Lock nut
5. Protective cap
6. Type code
7. Pressure rating (stamped on)
8. Marking (adjustment of zero position after the valve has been screwed in; subsequent fixing of the ring by a horizontal movement until it locks into place on the 6 A/F plug)
9. Fitting depth
10. Connection port P, optional
11. Connection port T, optional

Size	φ D1	D2	φ D3H9	φ D4
6	34	M28 × 1.5	25	6
10	38	M35 × 1.5	32	10
20	48	M45 × 1.5	40	20
30	63	M60 × 1.5	55	30

Size	φ D5	φ D6H9	φ D7	L1	L2	L3	L4	L5	L6	L7	L8	L9	L10	S	Light (kg)
6	15	24.9	6	72	83	64.5	15	19	30	35	45	56.5	65	32	approx.0.4
10	18.5	31.5	10	68	79	75	18	23	35	41	52	67.5	80	36	approx.0.5
20	24	39.9	20	65	77	106	21	27	45	54	70	91.5	110	46	approx.1
30	38.75	54.9	30	83	-	131	23	29	45	60	84	113.5	140	60	approx.2.2

Unit dimensions: for pipe mounting

(Dimensions in mm)

Adjustment element see front page

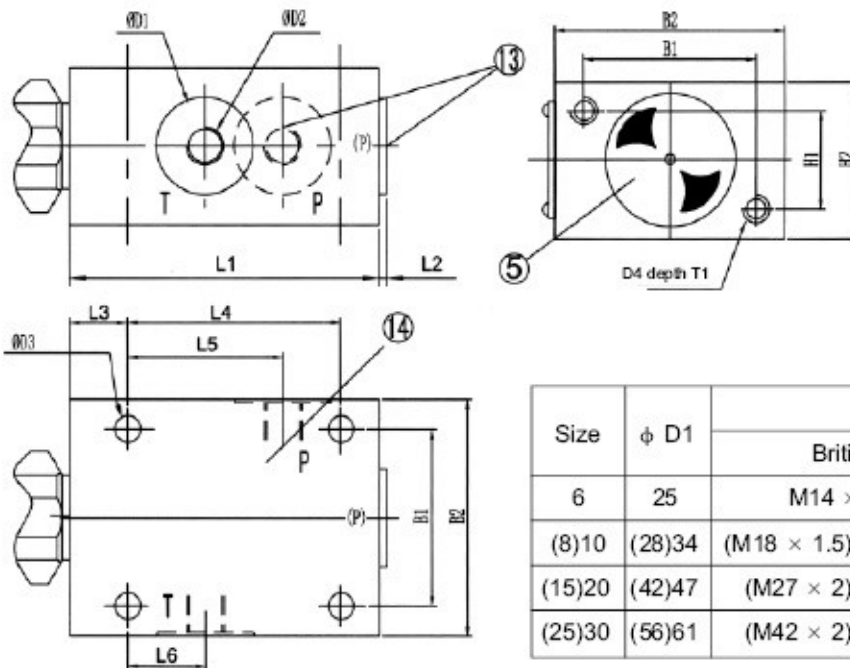

Size	φ D1	D2	
		British	Metric
6	25	M14 × 1.5	G1/4"
(8)10	(28)34	(M18 × 1.5)M22 × 1.5	(G3/8")G1/2"
(15)20	(42)47	(M27 × 2)M33 × 2	(G3/4")G1"
(25)30	(56)61	(M42 × 2)M48 × 2	(G1 1/4")G1 1/2"

Size	φ D3	D4	B1	B2	H1	H2	L3	L4	L5	L6	L7	L8	T1	Weight (Kg)
6	6.6	M6	45	60	25	40	80	4	15	55	40	20	10	approx. 1.5
(8)10	9	M8	60	80	40	60	100	4	20	70	49	21	20	approx. 3.7
(15)20	9	M8	70	100	50	70	135	5.5	20	100	65	34	20	approx. 6.4
(25)30	11	M10	100	130	60	90	180	5.5	25	130	85	35	25	approx. 13.9

Unit dimensions: for pipe mounting

(Dimensions in mm)

Adjustment element see front page

Rest dimension see the pipe mounting

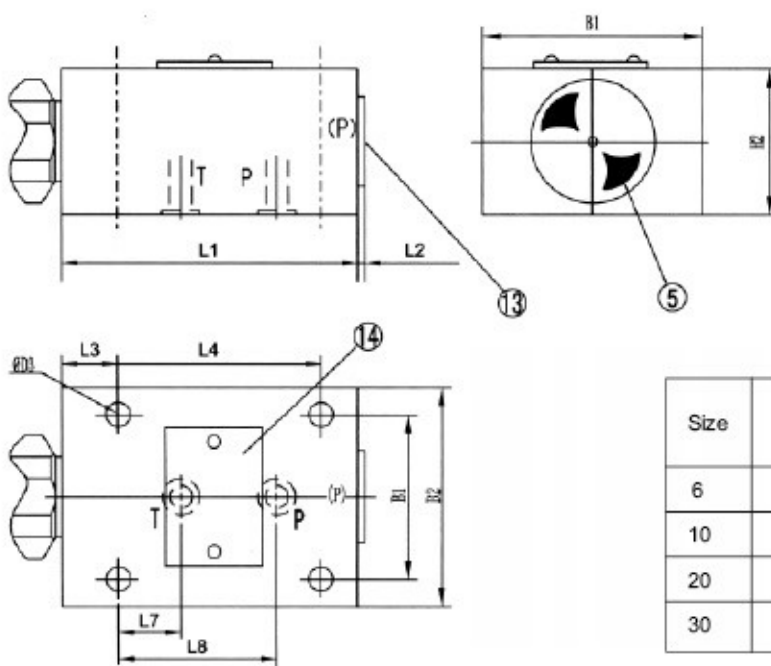

- Adjustment element "S" hex. head screw with protective cap
 - Connection port "P", optional (e.g. for pressure measuring)
 - Nameplate
- Subplate see page 148

Size	L7	L8	Subplate	Valve fixing screws GB/T 70.1-2000
6	20	40	G300/1	M6 × 50-10.9
10	21	45	G302/1	M8 × 70-10.9
20	34	65	G304/1	M8 × 90-10.9
30	35	85	G306/1	M10 × 110-10.9

NOTICE

1. The fluid must be filtered. Minimum filter fineness is 20 μm .
2. The tank must be sealing up and an air filter must be installed on air entrance.
3. Products without subplate when leaving factory, if need them, please ordering specially.
4. Valve fixing screws must be high intensity level (class 10.9). Please select and use them according to the parameter listed in the sample book.
5. Roughness of surface linked with the valve is required to $\sqrt{0.8}$.
6. Surface finish of mating piece is required to 0.01/100mm.